



## JTGK-800i+ CNC Machining Center

### Product descriptions and features

#### ■ Features

- new design of machine structure improves machine rigidity and machining stability
- Good chip removal method, which is suitable for different processing requirements
- Mature vibration suppression technology increases tool life
- Large stroke processing to meet the needs of more size products

#### ■ For Material

copper, aluminum, steel, stainless steel, etc

#### ■ Applied Range

machining of high surface requirement industries such as automotive, electrode, accurate mold, etc



KEJIE website



KEJIE wechat

## Parameters

Item	Parameter
X/Y/Z travel	700/800/450mm
Work table dimension	750×800mm
Max load of worktable	800kg
Spindle power/Max spindle speed	11.4kW/15000rpm 15kW/24000rpm
Spindle interface/taper	BBT40 BT30/BBT30
Rapid traverse rate	20m/min
Cutting feed rate	15m/min
Positioning accuracy	0.008mm/300mm
Repeatability	0.005mm
Machine net weight	6000kg (Chain type tool magazine) 6400kg (Circular type tool magazine)
Machine net dimension	2400×2370×2920mm(Chain type tool magazine) 2540×2370×2920mm(Circular type tool magazine)
Power supply	3-PH AC380V ±5% (50Hz)

## Standard Accessories

- High speed CNC controller
- High speed spindle
- AC servo motor
- Precision ball screw and guide rail
- Automatic tool magazine
- Automatic tool setter
- Spindle cooling system

## Optional Accessories

- Oil mist collector
- Voltage stabilizer
- 4-axis rotary table

Chain type tool magazine

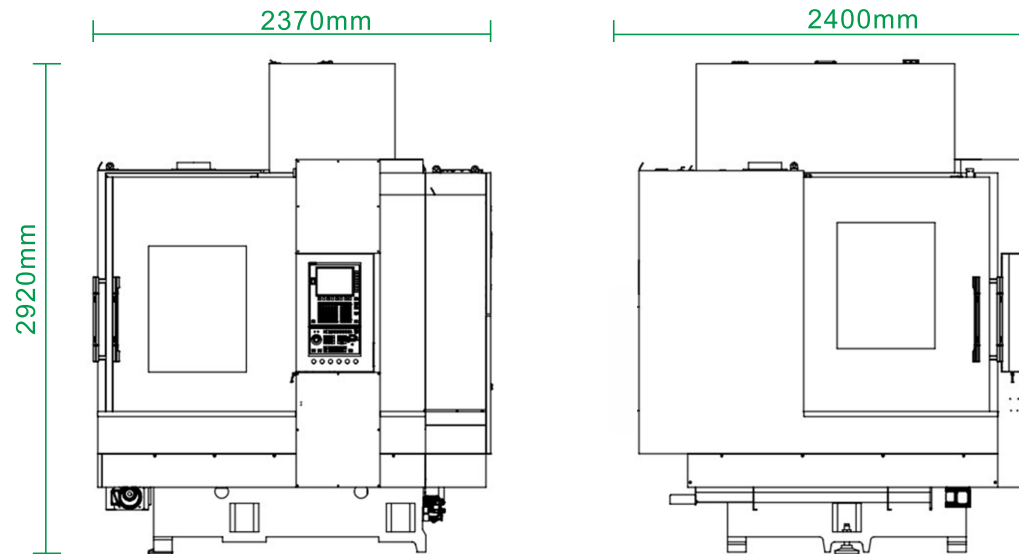

Circular type tool magazine

