

JTHS-600Au Machine Tool Intelligent Solution

Product descriptions and features

■ Features

- JIATIE independently developed NC system, better suits to the user's operating habits
- Temperature technology makes the machine long-time accuracy stable
- Brand new structure design improves machine rigidity and makes the machining performance more outstanding.
- Excellent chip drainage method, suitable for different machining demands.
- Brand new anti-vibration technology improves tool service life.
- Excellent dynamic machining performance
- High-speed and high-accuracy machining quality.
- All-in-one design, humanized human-machine interaction interface, easy operation.
- Fully closed loop system, maintains high accuracy

■ For Material

Graphite, copper, aluminum, steel, stainless steel, etc

■ Applied Range

Mold and component automatic machining



KEJIE website



KEJIE wechat

Parameters

Item	Parameter
X/Y/Z travel	600/500/300mm
Work table dimension	650×500mm
Max load of worktable	300kg
Spindle power/Max spindle speed	7.2kW/26000rpm
Spindle interface/taper	HSK E40
Rapid traverse rate	15m/min
Cutting feed rate	10m/min
Positioning accuracy	0.003mm/300mm
Repeatability	0.002mm
Machine net weight	6500kg
Machine net dimension	2260×2130×2470mm
Power supply	3-PH AC380V ±10% (50Hz)

Standard Configuration

- High speed CNC controller
- High speed spindle
- AC servo motor
- Automatic tool setter
- Hand Wheel
- Spindle cooling system

Optional Accessories

- Oil mist collector
- Automatic probe
- Voltage stabilizer

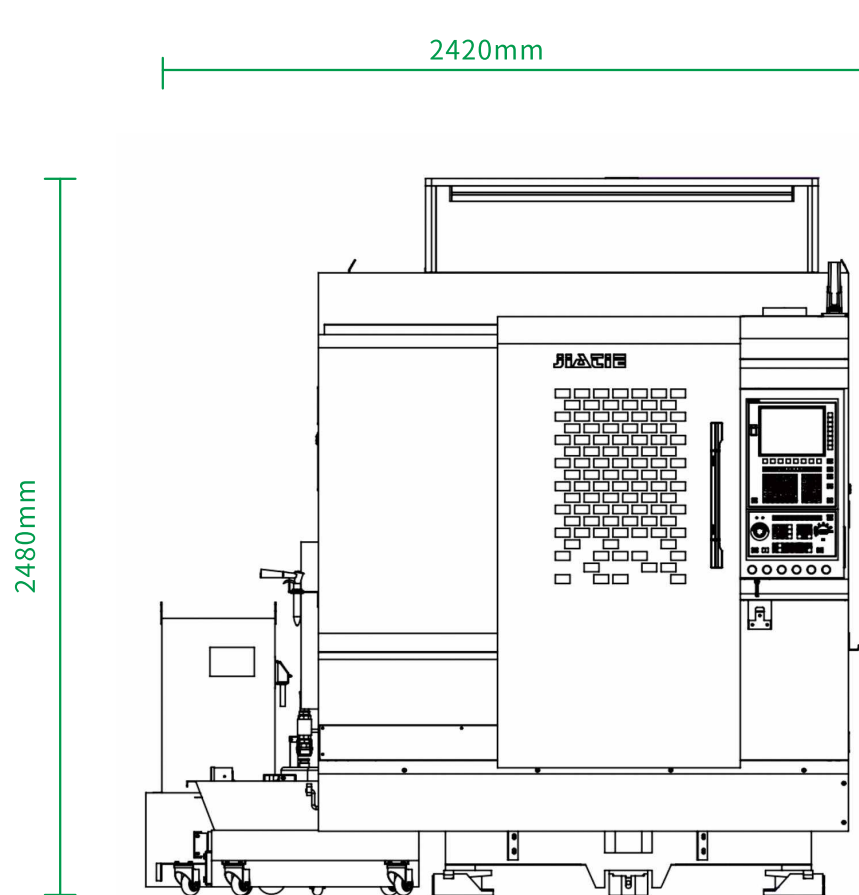

Front

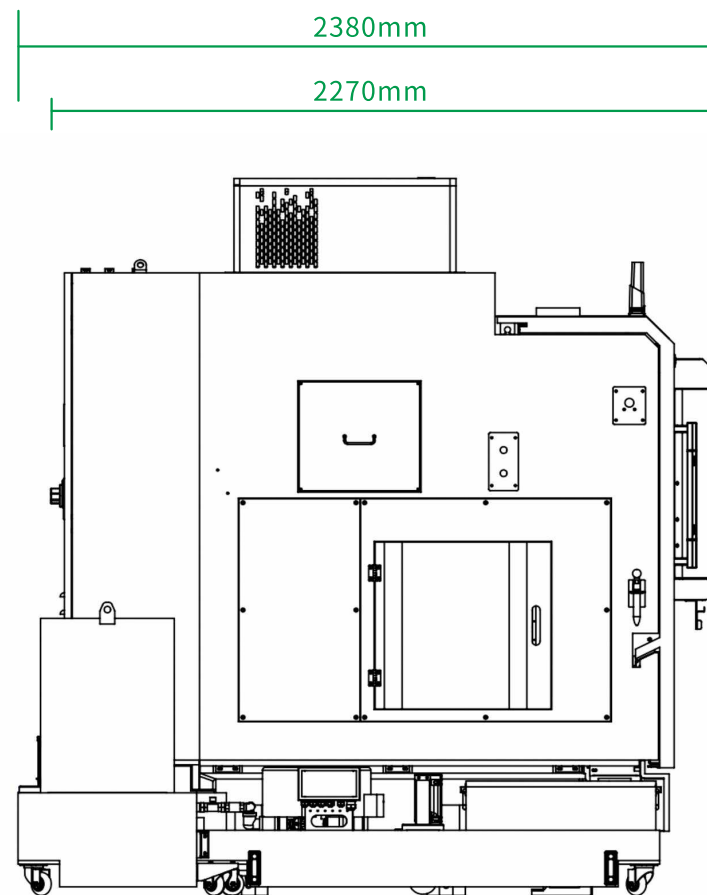

Left