

JTGK-800G CNC High Speed Machine

Product descriptions and features

■ Features

- New generation CNC controller
- JIATIE temperature control technology for precision stability
- Mature technology of vibration suppression, improve the tool life
- New structural design increases the machine rigidity. Stable and reliable
- Favorable chip removal for different machining requirements
- Many optional configurations can be selected for different functional requirements

■ For Material

special copper, aerospace aluminum, high hardness steel, quenched material, etc

■ Applied Range

mold inserting part, accurate electrode, accurate component machining



科杰技术网站



科杰技术公众号

Parameters

Item	Parameter
X/Y/Z travel	800/700/400mm
Work table dimension	850×700mm
Max load of worktable	800kg
Spindle power/Max spindle speed	26.8kW/20000rpm
Spindle interface/taper	HSK A63
Rapid traverse rate	15m/min
Cutting feed rate	10m/min
Positioning accuracy	0.008mm/300mm
Repeatability	0.005mm
Machine net weight	10000kg
Machine net dimension	2370×2630×2730mm (Circular type tool magazine) 2690×2630×2730mm (Chain type tool magazine)
Power supply	3-PH AC380V ±10% (50Hz)

Standard Accessories

- High speed CNC controller
- High speed spindle
- AC servo motor
- Precision ball screw and guide rail
- Automatic tool magazine
- Automatic tool setter
- Spindle cooling system

Optional Accessories

- High accuracy package (FAGOR Nano level grating scale/Precise level cutting fluid cooling/High-speed and high-accuracy machining mode)
- NC system (SIEMENS 828D)
- Oil mist collector
- Voltage stabilizer
- Automatic probe

Circular type tool magazine

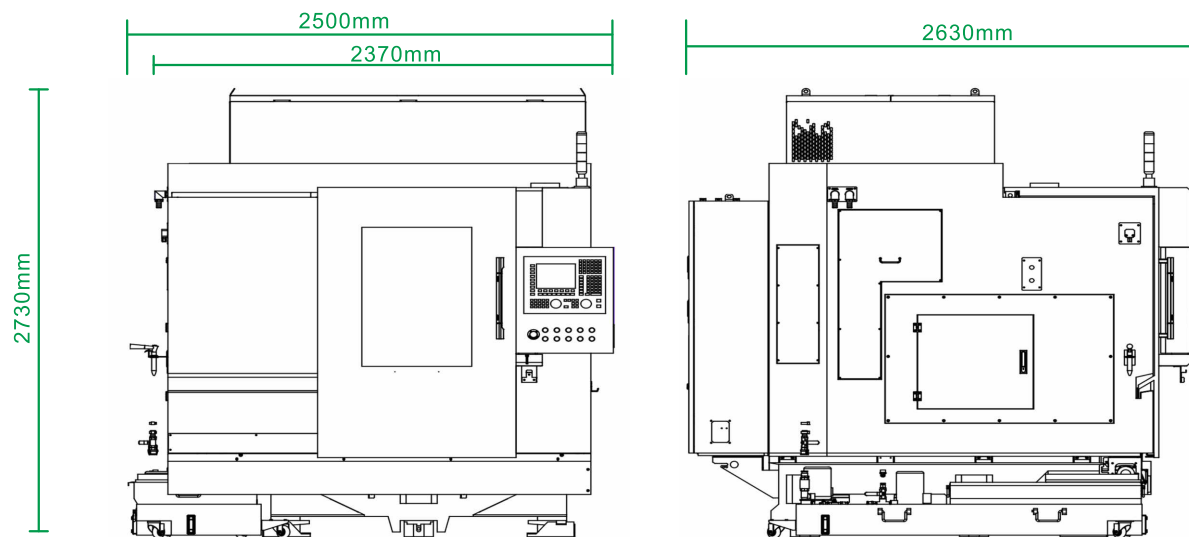

Chain type tool magazine

